

CAST IRON WEDGE- GATE VALVES WITH SMOOTH PORT

DN350-500 PN10 – 16

Fig.111UG

PS 16 bar

Approved for application:

Technical and Production Director - mgr inż. Jan Jurasz

FLANGE GATE VALVES –OPERATION AND MAINTENANCE MANUAL				
Made by	T. Włoch,	14.02.2022		PRODUCER/OWNER OF THE PRODUCT METALPOL WĘGIERSKA GÓRKA
Checked by	M. Dyrłaga	14.02.2022		
Approved by	J. Karpiński	14.02.2022		

Table of Contents:

1. TECHNICAL DESCRIPTION

- 1.1. Name and features of the product.
- 1.2. Intended use
- 1.3. Design and Operation
- 1.4. Tightness class
- 1.5. Materials
- 1.6. Durability
- 1.7. Technical approvals and certificates
- 1.8. Applicable norms and regulations

2. DESIGN VARIATIONS

3. MARKING OF GATE VALVES

4. ASSEMBLY AND OPERATION

- 4.1 Protection during the transport
- 4.2. Installation in the pipeline
- 4.3. Operation and maintenance

5. PROCEEDING DURING THE REMOVAL OF THE GATE VALVE

6. GUARANTEE

1. TECHNICAL DESCRIPTION

1.1. Name and features of the product.

The subject of the Operation and Maintenance Manual is:

The wedge-gate valve with smooth port made of the ductile cast iron with the following features

- full and even port
- elastomer-coated closing panel
- non- rising stem
- internal stem thread

1.2. Intended use

The gate-valves described as in point 1.1. are designed for closing and opening of the flow of clean liquids, including the clean drinking water, not chemical, non-polluted with solids, of the maximum temperature of factor up to 70⁰ C and nominal pressure up to 16 bar. Gate valves described above can be installed in the underground and ground pipeline. (horizontal or vertical).

Table 1 – Ranges of pressure, temperatures

DN	Size of flange end connections	External leak tightness pressure	Seat tightness pressure	Maximum water flow speed	Allowable temperature of the factor
	PN	[bar]		m/s	⁰ C
350-500	10	17	11	3	70
	16	25	18	4	

1.3. Design and operation (Fig.1, Tab.2)

The main elements of the gate valve are shown on the Fig.1 .

The internal part of the gate valve the so called coat consists of the body and the bonnet that are bolted together; the connection is tightened with the use of a special profile gasket.

The body of the gate-valve has a shape of flange tee, in which the pipeline part has the main outlet of a circular cross-section (full and even), whereas the branch has the oval cross-section. The outlets have flanges for connection to the pipeline. The oval branch has the oval flange for connection to the bonnet.

The internal diameter of the main waterway, known as the gate valve nominal dimension and denoted by "DN" is standardised; also the length of the FTF and the flange connection are standardised.

The oval outlet of the body constitutes the chamber in which the closing resilient rubber (wedge) is moving. The wedge is the element that closes the waterway and is strictly matched to the recess of a special shape which is situated in the oval part and divides the main waterway. Furthermore in the oval part, in a plane perpendicular to the axis of the main waterway, there are guides in which there are the wedge slides. The wedge guides and slides force the wedge's sliding motion and also protect the wedge from excessive vibration transferred from the flowing factor.

The bonnet has a shape of dome to which the bearing insert with the brass sleeve is mounted. In the insert there is a brass sleeve which fix the position of the stem. The pairs insert/sleeve, sleeve/stem are sealed with O-ring. The monolithic stainless steel stem has got the thrust flange that operates as the thrust slide bearing and stabilises the stem's longitudinal position. The section of the stem that is placed inside the valve body under the flange has rolled trapezoidal thread that matches the thread on brass nut embedded in the rubber encapsulated wedge. The section of the stem above the valve bonnet is terminated with a square head which can be use for installation a hand wheel (in the gate valves for the ground pipelines) or a square operating cap (in the gate valves for the underground pipelines).

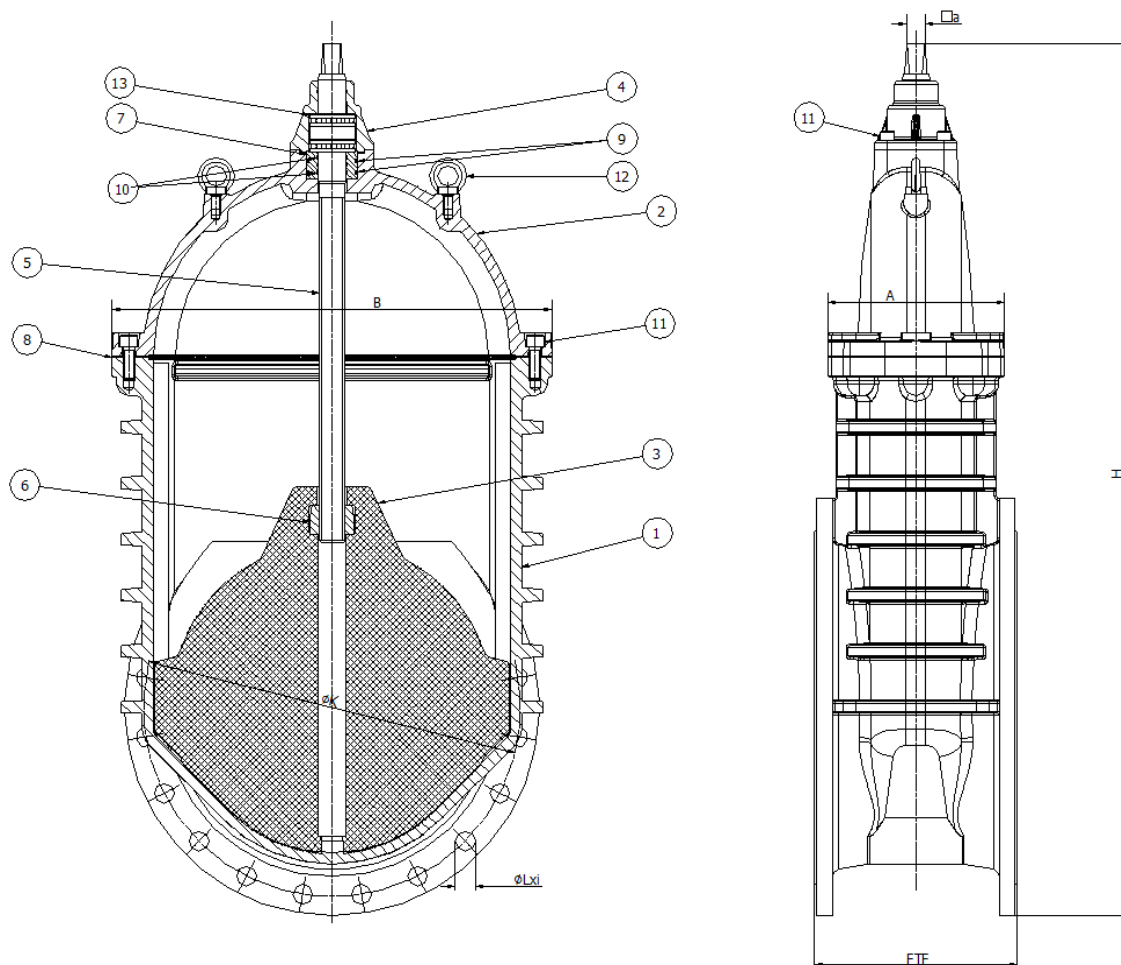

Fig. 1 – The construction of the wedge-gate valve

- | | |
|----------------------|---|
| 1 – body | 7 – sleeve |
| 2 – bonnet | 8 – body bonnet seal |
| 3 – resilient thread | 9 – the sealing of the sleeve with the bonnet |
| 4 – bearing insert | 10 – stem sealing |
| 5 – stem | 11 – internal wrenching bolts |
| 6 – stem nut | 12 – bolt |
| | 13 – bearings |

Tab. 2 – Wedge-gate valves dimensions.

DN	FTF Width 14	D (mm)	K (mm)		d (mm)		C (mm)	f (mm)	L (mm)		i		a (mm)	D _k (mm)	A (mm)	B (mm)	H (mm)	Weight (kg) *
			PN 10	PN 16	PN 10	PN 16			PN 10	PN 16	PN 10	PN 16						
350	290	520	460	470	430	430	26,5	4	23	28	16	16	27,4	500	252	564	1131	235
400	310	580	515	525	480	480	28	4	28	31	16	16	27,4	500	262	616	1232	300
500	350	715	620	650	582	609	31,5	4	28	34	20	20	32,4	640	304	758	1495	515

* - weight without handwheel; the deviations from the nominal weight of valves within $\pm 5\%$.

Table 3 – Handwheel diameter, number of turns.

DN	D _K	Tr – LH	□ a Stem pivot	II. turn of the stem from the full opening to the full closing
mm				1/n
350	500	32 x 6	27	59
400	500	32 x 6	27	67
500	640	44 x 8	32	63

Table 4 – Gate valves opening and closing torque

DN	Opening and closing torque (Nm)
350	250
400	250
500	350

Table 5 – Dimensions of sealing rings

DN	Sealing O-ring	
	D x d (mm)	Pcs.
350-400	32,2 x 3	3
	40,2 x 3	1
500	45,2 x3	3
	58,0 x3	1

Under and above the stem's flange there are bearings that lower the friction between the flange and the insert with the brass sleeve. Rotary motion of the handwheel is transferred to the stem and converted by the wedge nut to progressive motion of the wedge. Turning the handwheel clockwise closes the gate valve while turning it counter-clockwise opens the gate valve. The directions to open/close the valve are marked on the handwheel.

In gate valves designed for underground operation, closing and opening is done by a special 'T' spanner. In this design the stem is extended to ground surface and protected by housing and the stem's head and valve bonnet are inside a cast iron street box. Stem extension, street box and valve housing are separate parts and are not included to the gate valve; they can be delivered on customer's request.

Note: On customer's request, the gate valves may be produced with optional mechanism that allows closing of the gate valve by counter-clockwise turning of the handwheel

1.4. **Tightness class**

Gate valves as described herein in the pressure range shown in Table 1 and in the conditions of room temperature (20⁰C) have been categorised as class B devices according to EN-12266-1 Tab.A5, which means that the gate valves during the leak test cannot develop a visible leakage bigger than 0,01 x DN mm³/s.

Nominal pressure and tightness test pressures are given in Table 1.

1.5. Materials.

- Valve body, bonnet, wedge casting bearing insert - ductile iron
- Handwheel - grey cast iron
- Stem - stainless steel
- Sleeve, stem nut sliding rings - brass
- wedge lining, O-rings, oval gaskets - rubber
- Connections - carbon steel, galvanized
- Corrosion resistant coating - epoxy paint

Note: Material types and requirements are given in 'Spare parts list', which is a constituent of the design documentation for each product

1.6. Durability

Durability of isolating valves:

- valves with manual drive: 250 "opening / closing" cycles;
- valves with electric, hydraulic or pneumatic drive: 2500 "opening / closing" cycles

1.7. Technical approvals, certificates

CE Certificate
PZH Hygienic Certificate

1.8. Applicable norms and regulations

- PN-EN 19 - Industrial valves – Marking of metal valves.
- PN-EN 558-1: - Industrial valves. Face-to-face and centre-to-face Dimensions of metal valves for use in flanged pipe systems
-
- PN-EN 681-1 - Elastomeric seals. Rubber.
- PN-EN 736-2 - Valves. Terminology.
- PN-EN 1074-1 - Valves for water supply. Fitness for purpose requirements and appropriate verification test. Part 1: General requirements.
- PN-EN 1074-2 -Valves for water supply. Fitness for purpose and appropriate verification test Part 2: Isolating valves.
- PN-EN 1092-2 - Flanges and their joints. Circular flanges for pipes, valves, fittings, and accessories, PN designated. Cast iron flanges.
- PN-EN 1171 - Industrial valves. Cast iron gate valves.
- PN-EN 1563 - Founding. Spheroidal graphite cast irons.
- EN 12266-1 - Industrial valves. Testing of valves. Part 1. Mandatory requirements.
- EN 12266-2 - Industrial valves. Testing of valves . Part 2. Supplementary requirements.

- PN-EN 12420 - Copper and cast copper alloys. Forging.
- PN-ISO 8062-1 - Castings. System of dimensional tolerances and machining allowances.
- PN-EN 12570 - Industrial valves. General requirements and testing.
- PN-63/M-74085 - „Industrial valves. Key for valves and hydrants”.

2. Design variations

In order to meet the market requirements, the gate valves are manufactured in two additional design variations:

- a) valves adjusted to the electromechanical drives according to ISO 5210 – denoted by a catalogue number.../986.

The example of marking: Gate valve DN350 catalogue number. 111 –UG/986

- b) gate valves with worm gearing- denoted by a catalogue number 972.

The example of marking: Gate valve DN350 catalogue number. 111 –UG/972

Tab. 6 – Dimensions for electromechanical drive and the worm gearing.

DN	Flange size	Flange type	Flange outer diameter (mm)	Bolt distance diameter (mm)	Bolt diameter / no. of bolts (M x i)	Stem pivot diameter (mm)	Groove b x h x l (mm)
350 400 500	F14	B3 ISO 5210	175	140	16 x 4	30f8	8 x 7 x 63

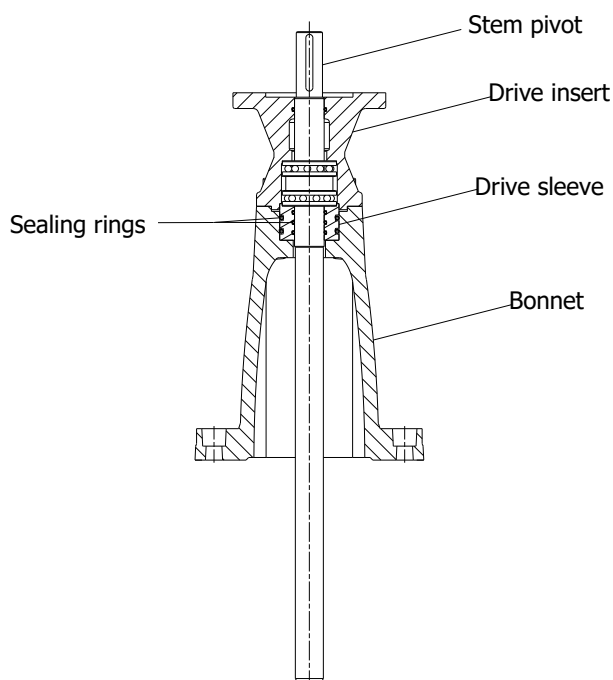

Fig. 2 – Wedge- gate valves adjusted to the electromechanical drive and worm gearing according to ISO 5210.

The basic construction, used materials, the intended use, the scope of tests and requirements are the same for each variation.

The design variations described above are adjusted to the size of the flange connections PN10 and PN16. The size of the flange connections of the gate valve are to be determined by the customer in the order. The size of the flange connections is not marked with any differentiator in the catalogue number.

3. MARKING OF GATE VALVES

3.1. Marking of gate valves is determined by the following standards: EN-19, EN-1074-1, PN-EN 19.

3.2. All markings are permanently engraved on both sides of gate valve body. Marking shall include the following information:

- DN – nominal diameter
- Material type according to PN-EN 1563
- Manufacturer's logo
- CE marking
- Year of production
- Number of the specified standard
- PN – marking of the connecting flanges size according to EN 1092-2,

4. ASSEMBLY AND OPERATION

4.1. Protection during the transport and storage.

The gate valve is delivered in closed position (the closing component in its lower position, slightly pressed) with all openings fully sealed.

Transport and storage should be done in a manner that does not present a risk of damage to paint coating, soiling of internal part or the valve's body with any fine, sharp particles (gravel, stones, steel shavings etc.) or aggressive chemical substances or other substances that can pollute water passing the waterway.

Gate valves must not be stacked as this could lead to damage of paint coating, damage of the handwheel, deformation of the stem, which could, in turn, lead to loss of tightness of the gland.

For storage of gate valves in horizontal layers, use rigid spacers, strips, cardboard, foam, etc.

Gate valves must be properly fastened during the transport to prevent displacement and possible damage

For transportation of the gate valves of large weight (DN 300 and larger) use mounted transport elements– bolts with eye and for a smaller sizes than DN300 use sling belts with protection against the possibility of rotating the gate valve. Never attach a sling to the gate valve's driving elements (handwheel, cap, motorbase, stem head) or any flange connection holes or to flange.

Gate valves are recommended to be moved in the following manner:

DN≥300

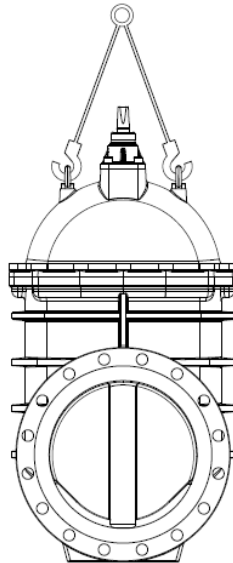

4.2. Assembly in the pipeline.

Gate valves described herein can be installed in above ground or underground pipelines (horizontal or vertical); gate valves DN350-500 are recommended for installation in horizontal pipelines in an upright position only.

Gate valves shall be installed in such a way that they are not subject to shearing forces in the pipeline. Pipeline designer should indicate the proper installation configuration.

When installed in an underground pipeline directly in the ground, it is recommended that gate valve rests on a concrete foundation, this applies especially to gate valves of bigger sizes.

When installed in above ground pipelines, gate valve should rest on a support or concrete foundation which should be predicted in the design project.

Prior to installation, it is recommended to check the condition of the internal surface of the gate valve and clean it carefully with the use of water if necessary.

. All works related to transportation, excavation and installation must comply with health and safety regulations.

Note: Any debris and sharp particles on the surface of the closing component or seat may cause damage to sealing surfaces and loss of tightness. During the test filling of the waterway with water the gate valves should have passages opened.

4.3. Operation and maintenance

The gate valves described herein do not require any special operations or maintenance.

In case of loss of tightness of the passage closure, the following steps must be taken:

- cut off the water supply in the pipeline,
- open the gate valve,
- withdraw the internal unit and inspect the surfaces of the closing component and seats in the body,
- in case of damage of the closing component it ought to be replaced,
- in case of permanent damage of the seats in the body, the body should be replaced.
- the assembly shall be performed in the opposite orders according to the principles as during the test filling of the pipeline,
- prior to covering with the ground the additional insulation should be put on
-

Note: The manufacturer shall not be liable for damages caused as a result of an improper transport and assembly of the gate valve, operation of the gate valve that does not comply with this Operation and Maintenance Manual or caused by the foreign bodies.

5. PROCEEDING DURING THE REMOVING THE GATE VALVE (RECYCLING)

Never it was found that any part of gate valves produced by METALPOL WĘGIERSKA GÓRKA Sp. z o.o., has a negative influence on environment, people and animals. This fact is confirmed by Hygienic Certificate issued by PZH in Warsaw. None of the parts of gate valve in chemical composition holds substances from the list of Substances of Very High Concern SVHC. In case of removing the gate valve, each part of the gate valve is subjected to recycling and as a raw material it may be used in the other manufacturing process.

Please note that sediment gathered inside the valve or the pipeline may be dangerous for people or the environment. Therefore the adequate safety requirements must be followed. At the end of lifecycle the valve must be disposed in accordance to the adequate environmental safety regulations.

6. GUARANTEE

The manufacturer's guarantee covers the products installed and used according to the rules indicated in this Document. The detailed conditions of the guarantee are included in " Guarantee Conditions" attached to the price list.

Tampering with products (changes, replacement of parts, loosening original connections, etc.) is not permitted and causes the expiration of the guarantee obligations and product liability.