

CAST IRON GATE VALVES WITH CONNECTIONS TO PE PIPES

DN25-50 PN16

PFA 16 bar

GATE VALVES WITH CONNECTIONS TO PE PIPES- TECHNICAL AND OPERATION MANUAL			
Made by	T. Włoch	22.07.2022	PRODUCER/OWNER OF THE PRODUCT METALPOL
Checked by	M. Dyrłaga	22.07.2022	
Approved by	J. Karpiński	22.07.2022	

Table of contents:

1. TECHNICAL DESCRIPTION

- 1.1. Name and features of the product
- 1.2. Intended use
- 1.3. Design and operation
- 1.4. Tightness class
- 1.5. Technical approvals and certificates
- 1.6. Applicable norms and regulations

2. DESIGN VARIATIONS

3. ASSEMBLY AND OPERATIONS

- 3.1. Protection during the transport
- 3.2. Installation in the pipeline
- 3.3. Operation and maintenance
- 3.4. Proceeding during the removal of the gate valve

4. GUARANTEE

1. TECHNICAL DESCRIPTION

1.1. Name and features of the product.

The subject of the Operation and Maintenance Manual is:

The gate valve DN25-50 with connections to PE pipes made of ductile iron with:

- full and even port
- elastomer-coated closing port
- non-rising stem
- internal stem thread
- soft sealing of the stem in the cover

1.2. Intended use

Gate valves with PE connections are designed for installations of the clean drinking water or process water of temperature up to do 70°C and pressure to 16 bar. Closing the gate valve takes place by turning the stem clockwise. The gate valves can be installed in the horizontal and vertical pipelines.

Table 1 – Ranges of pressure, temperatures and speed of the factor flow.

DN	Allowable working pressure	External leak tightness pressure	Seat tightness pressure	Allowable temperature of the factor
				⁰ C
25-50	16	25	18	70

1.3. Design and operation (Fig.1, Tab.2, Tab.3)

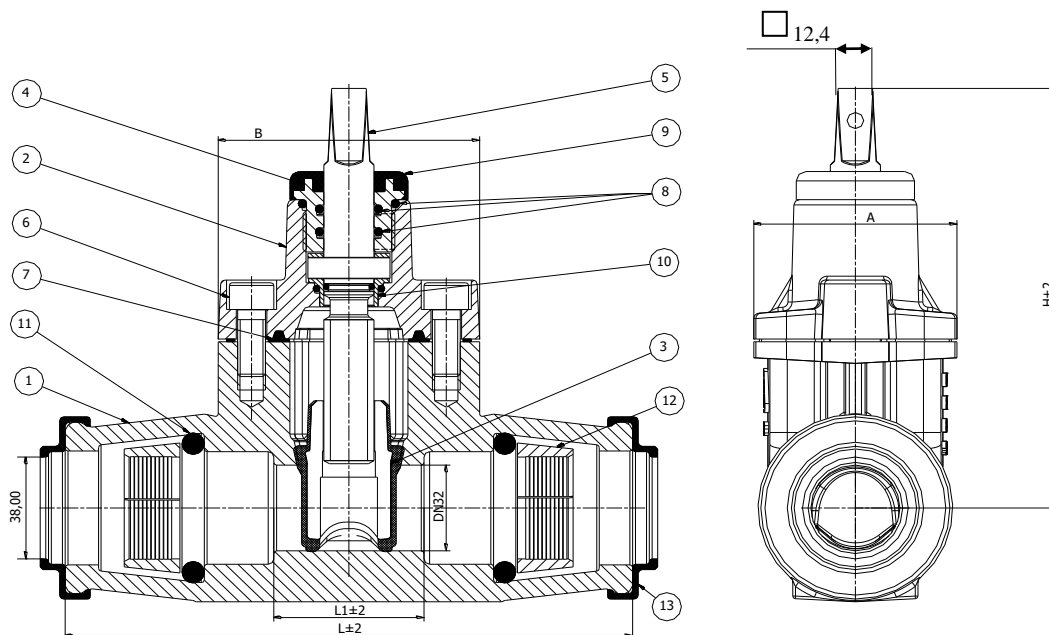

Fig. 1 The construction of the gate valve with connections to PE pipes.

Table 2 –The list of construction elements- material.

No.	Name of the part	Used materials
1	Body	EN-GJS 500-7
2	Bonnet	EN-GJS 500-7
3	Rubberized wedge	CuZn39Pb2/NBR
4	Bush with thread	CuZn39Pb2
5	Monolithic stem with trapezoidal thread	X20Cr13
6	Hexagon- socket cap screw	Stainless steel
7	Sealing of the bonnet with the body	NBR
8	Sealing of the stem	NBR
9	Protection cap	NBR
10	Reversible sealing	CuZn39Pb2
11	Sealing of the pipe	NBR
12	Gripping ring	Poliacetal
13	Protection cap of the bowl	NBR

Table 3 – Dimensions of gate valves with connection for PE pipes.

DN	L [mm]	L1 [mm]	A [mm]	B [mm]	H [mm]	Diameter of pipe [mm]	Weight [kg]
25	175	54	73	94	160	32	3,20
32	205	55	73	94	156,5	40	3,75
40	255	76	78	138	190	50	4,95
50	300	82	78	138	190	63	6,98

Table 4 –Number of turnovers.

DN	Tr – LH	□ a Stem pivot	Leap of the closing component	II. turn of the stem from the full opening to the full closing
[mm]				1/n
25	18 x 4	12,4	35	8,75
32	18 x 4	12,4	35	8,75
40	18 x 4	12,4	46	11,5
50	18 x 4	12,4	54	13,5

Table 5 – Gate valves closing/opening torques.

DN	Maximum closing torque (Nm)
25	48
32	48
40	48
50	48

1.4. Tightness class

Gate valves as described herein in the pressure range shown in Table 1 and in the conditions of room temperature (200C) have been categorised as class A devices according to EN-12266-1.

1.5. Technical approvals, certificates

PZH Hygienic Certificate

1.6. Applicable norms and regulations

- PN-EN 19 - Industrial valves – Marking of metal valves.
- PN-EN 558-1 - Industrial valves. Face-to-face and centre-to-face Dimensions of metal valves for use in flanged pipe systems
- PN-EN 1563 - Founding. Spheroidal graphite cast irons
-
- EN 12266-1 - Industrial valves. Testing of valves. Part 1. Mandatory requirements.
-
- EN 12266-2 - Industrial valves. Testing of valves. Part 2. Supplementary requirements.
- PN-EN ISO 228-1- Pipe Threads where Pressure-tight Joints are not made on the Threads
Part 1: Dimensions, tolerances and designation

2. DESIGN VARIATIONS

- Gate valve UG-PE (SDR 11) DN25-50 with PE ferrules for heat-sealing (Fig.2, Tab.6).

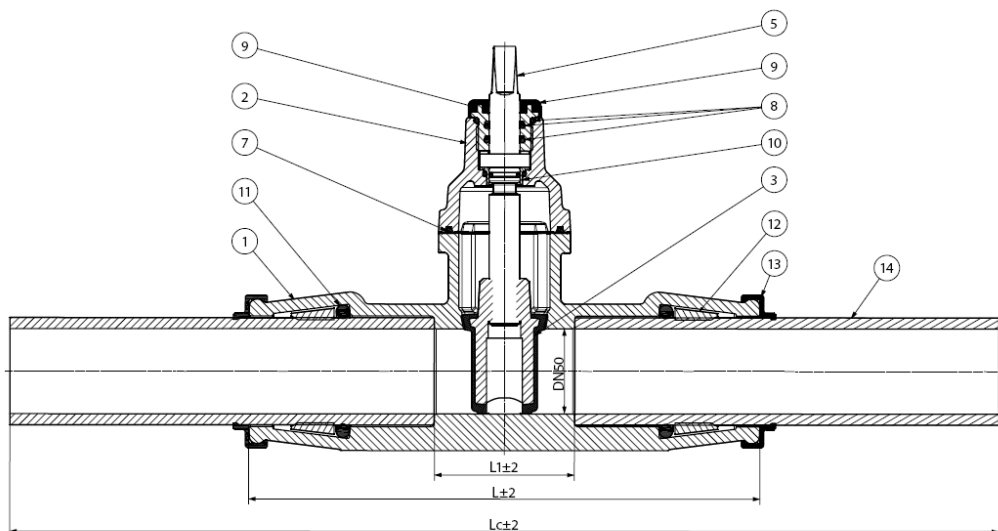

Fig. 2 The construction of the gate valve with PE ferrules for heat-sealing.

Table 6 – Dimensions of gate valves with PE ferrules for heat-sealing.

DN	L1 [mm]	L [mm]	Lc [mm]	A [mm]	B [mm]	H [mm]	Pipe diameter[mm]
25	54	175	575	73	94	160	32
32	55	205	605	73	94	156	40
40	76	255	655	78	138	190	50
50	82	300	700	78	138	190	63

3. ASSEMBLY AND OPERATION

3.1. Protection during the transport and storage.

The gate valve is delivered in open position. The gate valve is packed in a plastic bag and placed in cardboard box. Transport should be done in a manner that does not present a risk of permanent damage to external or internal protective coating. Valves should be stored in rooms, which are free from mechanical, chemical and bacteriological impurities.

3.2. Assembly in the pipeline.

Gate valves described herein can be installed in the horizontal or vertical pipelines. Gate valves shall be installed in such a way that they are not subject to bending moments from forces in the pipeline. Pipeline designer should indicate the proper installation configuration

Note: Any debris and sharp particles on the surface of the closing component or seat may cause damage to sealing surfaces and loss of tightness.

The proper diameter of the PE pipe should be used for the proper dimension of the gate valve. (Tab.7)

Table 7 – Pipes from the PE 100 class material, ratio SDR 11 for PN 16.

DN	External diameter of PE pipe [mm]	Max. deviation of the external diameter [mm]	Nominal thickness of the wall [mm]
25	32	0,3	3,0
32	40	0,4	3,7
40	50	0,5	4,6
50	63	0,6	5,8

Before the installation of the gate valves with PE pipes the endings of the pipe should be bevelled at an angle of 30° (Fig. 3). Then the PE pipes should be pressed into the bowl of the gate valve to resistance. After pressing the pipe fully into the bowl of gate the pipe should be pulled in the reverse direction in order to clamp the strengthening ring on the pipe. In order to protect the connection between the gate valve and the PE pipe, the rubber cap should be put on the bowl of the gate valve.

DN25-50 gate valves with PE ferrules (Fig. 2) are adjusted to be installed between the endings of the pipeline and are designed for connecting with the use of heat-sealing.

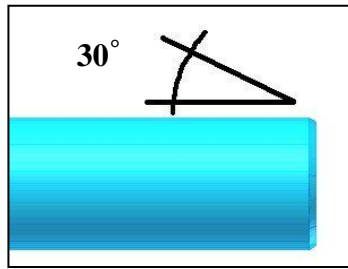

Fig. 3 Bevelling of the PE pipes.

During the trial filling of the pipeline with the water the gate valves should have the passages open.

2.3. Operation and maintenance

The gate valves described herein do not require any special operations or maintenance.

In case of wear of the sealing rings in the gland they can be replaced under the pressure without the necessity of cutting off the water supply. In order to replace the following steps must be taken:

1. open the gate valve completely,
2. unscrew the bush with thread,
3. replace the worn sealing "O"- rings,
4. check the surface of the upper slip ring and eventually replace it,
5. put the small amount of the protective oil for threads onto the bush thread in order to protect it against untwisting
6. screw the bush in completely.

In case of loss of tightness of the passage closure, the following steps must be taken:

- cut off the water supply in the pipeline,
- open the gate valve,
- withdraw the internal unit and inspect the surfaces of the closing component and seats in the body,
- in case of damage of the closing component it ought to be replaced,
- in case of permanent damage of the seats in the body, the body should be replaced.
- the assembly shall be performed in the opposite orders according to the principles as during the test filling of the pipeline,

Note: The manufacturer shall not be liable for damages caused as a result of an improper transport and assembly of the gate valve, operation of the gate valve that does not comply with this Operation and Maintenance Manual or caused by the foreign bodies.

Table 8 – Dimensions of sealing rings. Dimensions of wrenches.

DN	Sealing ring „O”		Dimension of wrench S (mm)
	D x d (mm)	Pcs.	
25 - 50	18,2 x 3	2	32
	21,3 x 3	1	
	29,3 x 3	1	
	14 x 2	1	

2.4. Proceeding during the removing the gate valve

Never it was found that any part of gate valves produced by METALPOL WĘGIERSKA GÓRKA Sp. z o. o., has a negative influence on the environment, people and animals. This fact is confirmed by Hygienic Certificate issued by PZH in Warsaw. None of the parts of gate valve in chemical composition holds substances from the list of Substances of Very High Concern SVHC. In case of removing the gate valve, each part of the gate valve is subjected to recycling and as a raw material it may be used in the other manufacturing process.

Please note that sediment gathered inside the valve or the pipeline may be dangerous for people or the environment. Therefore the adequate safety requirements must be followed. At the end of lifecycle the valve must be disposed in accordance to the adequate environmental safety regulations.

3. GUARANTEE

The manufacturer's guarantee covers the products installed and used according to the rules indicated in this Document. The detailed conditions of the guarantee are included in "Guarantee Conditions" attached to the price list.

Tampering with products (changes, replacement of parts, loosening original connections, etc.) is not permitted and causes the expiration of the guarantee obligations and product liability.